

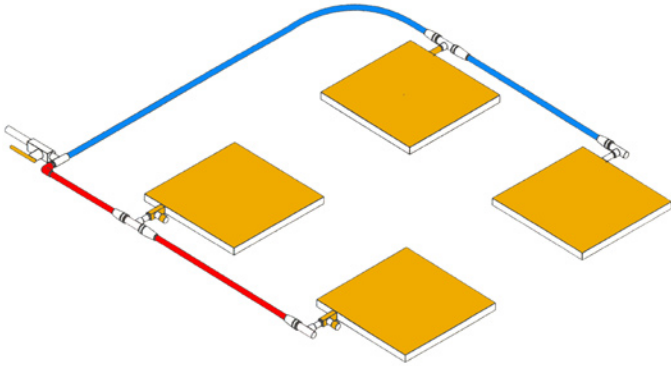

B-Type Air Bearing & Standard Aluminum Module Technical Specifications

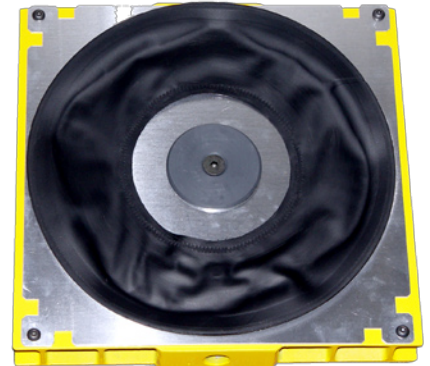

A typical B-bearing system footprint



B-bearing fitted to
Standard SA module

MODEL	BEARING	CAPACITY	DIMENSIONS IN INCHES			FLOW - SCFM		LOAD PAD	APPROX WEIGHT IN POUNDS	
			Number	Pounds	Diameter	Height Air Off	Height Air On		Half Load	Full Load
SA12-B	B12N	2,000	12	1.9	2.6	8	12	8	7	2
SA15-B	B15N	3,500	15	2.0	2.9	8	14	14	11	3
SA21-B	B21N	7,000	21	2.0	3.1	14	16	14	22	4

www.hovair.com